

DESIGN DATA:

1. MANHOLE COMPONENTS CONFORM TO ASTM C-478 AND AASHTO M-199
2. FLAT TOPS AND BASE SLABS ARE DESIGNED FOR H-20 TRAFFIC TO 30' STACK HEIGHT
3. TALLER DESIGNS AVAILABLE UPON REQUEST
4. THIS PRODUCT IS AN OVERSIZED LOAD AND REQUIRES ADVANCED NOTICE FOR SHIPPING

IPANEX

5. ALL CONCRETE IN THIS PRODUCT CONTAINS IPANEX, AN ADMIXTURE TO WATERPROOF THE CONCRETE AND PROVIDE CORROSION CONTROL

CASTING WEIGHTS

WEIGHT OF 60" LID:	12" = 3,000 LBS
WEIGHT OF 60" BASE:	32" = 5,615 LBS
WEIGHT OF 60" RISER:	48" = 5,200 LBS
WEIGHT OF 60" RISER:	PER INCH = 101 LBS

LIFT STATION CAPACITY:
12.23 GALLONS PER INCH

DOSING COMPARTMENT CAPACITY:
LIQUID STORAGE = VARIES
21.23 GALLONS PER INCH
MAXIMUM DOSE = XXX GALLONS (XX)
PUMP COOLING = XXX GALLONS (XX)
UNUSED (ALARM) = XX GALLONS (4)
TOTAL = XXX GALLONS (XX)

NOTES:

1. SET PUMP ON FLOAT SWITCH ELEVATION ACCORDING TO ELEVATION TABLE (BELOW); WHICH YIELDS THE REQUIRED DOSE VOLUME OF XXX GALLONS.
2. CONTRACTOR SHALL INSTALL CONTROL PANEL ACCORDING TO PUMP MANUFACTURER'S RECOMMENDATION.
3. COORDINATE POWER & ALARM SERVICE PRIOR TO CONSTRUCTION ACTIVITIES
4. ONLY NON-CORROSIVE MATERIALS SHALL BE UTILIZED WITHIN THE DOSING TANK AND FOR THE RISER AND LID (NO GALVANIZED, PAINTED, OR EXPOSED STEEL).
5. AUDIO VISUAL ALARM CIRCUIT MUST LOCK ON WITH ANY PUMP FAILURE WITH MANUAL RESET.

DOSING CHAMBER ELEVATIONS

DESCRIPTION	ELEVATION (FEET)
BOTTOM OF CHAMBER	0.00
PUMP OFF	1.08
PUMP ON	2.83
ALARM	3.17
LAG PUMP ON	3.50

NOTE:
24" DIAMETER POLY RISERS & LIDS OR CUSTOM RECTANGULAR RISERS WITH ALUMINUM HATCHES ARE AVAILABLE

RENSELAER SEPTIC TANKS

1211 NORTH WESTON STREET
P.O. BOX 70
RENSELAER, INDIANA 47978
phone: (219) 866-5063
(800) 240-5123
fax: (219) 866-3894

PROJECT NAME
CLIENT NAME
ADDRESS

PROJECT NO: ---
FILE: TR-MH60-DUPLEX.DWG
DRAWN BY: ASJM
CHECKED BY: PEW
TITLE:
**MANUFACTURER'S
DETAIL DRAWING**
60" LIFT STATION
DUPLEX DOSING
TRAFFIC RATED

R-000

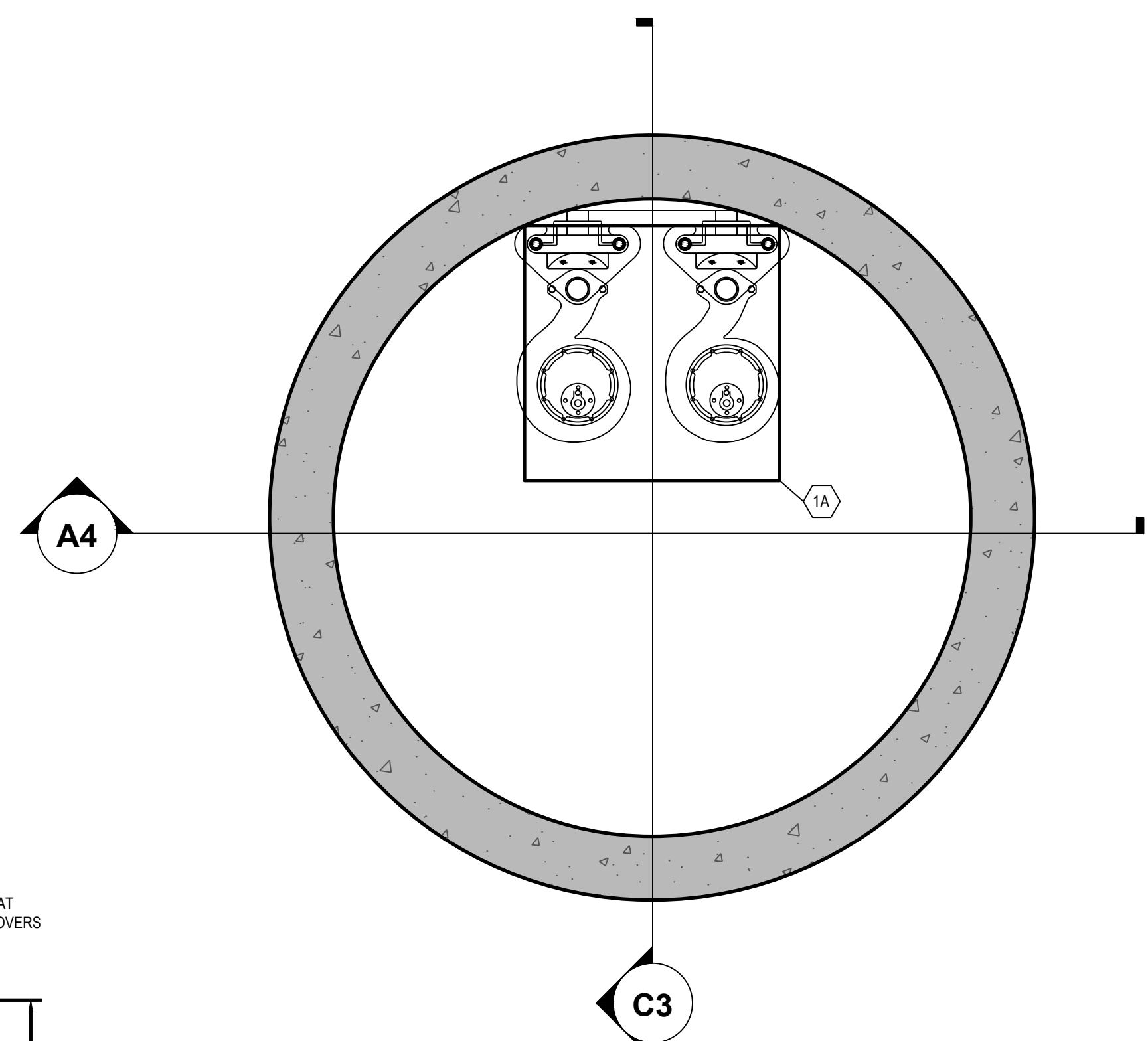

D4 LIFT STATION TOP VIEW
1" = 1"

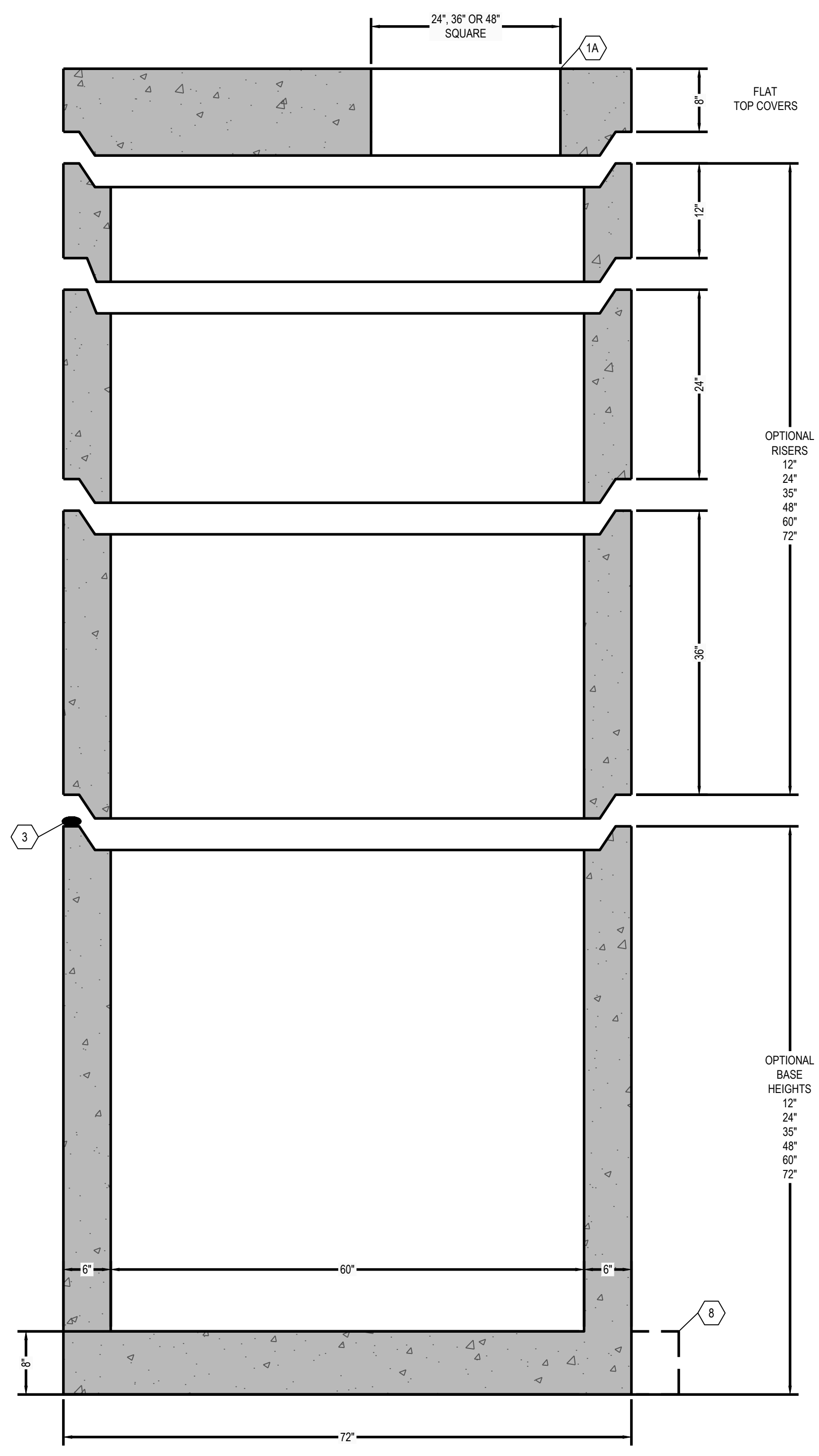

A6 LIFT STATION SECTION VIEW
1" = 1"

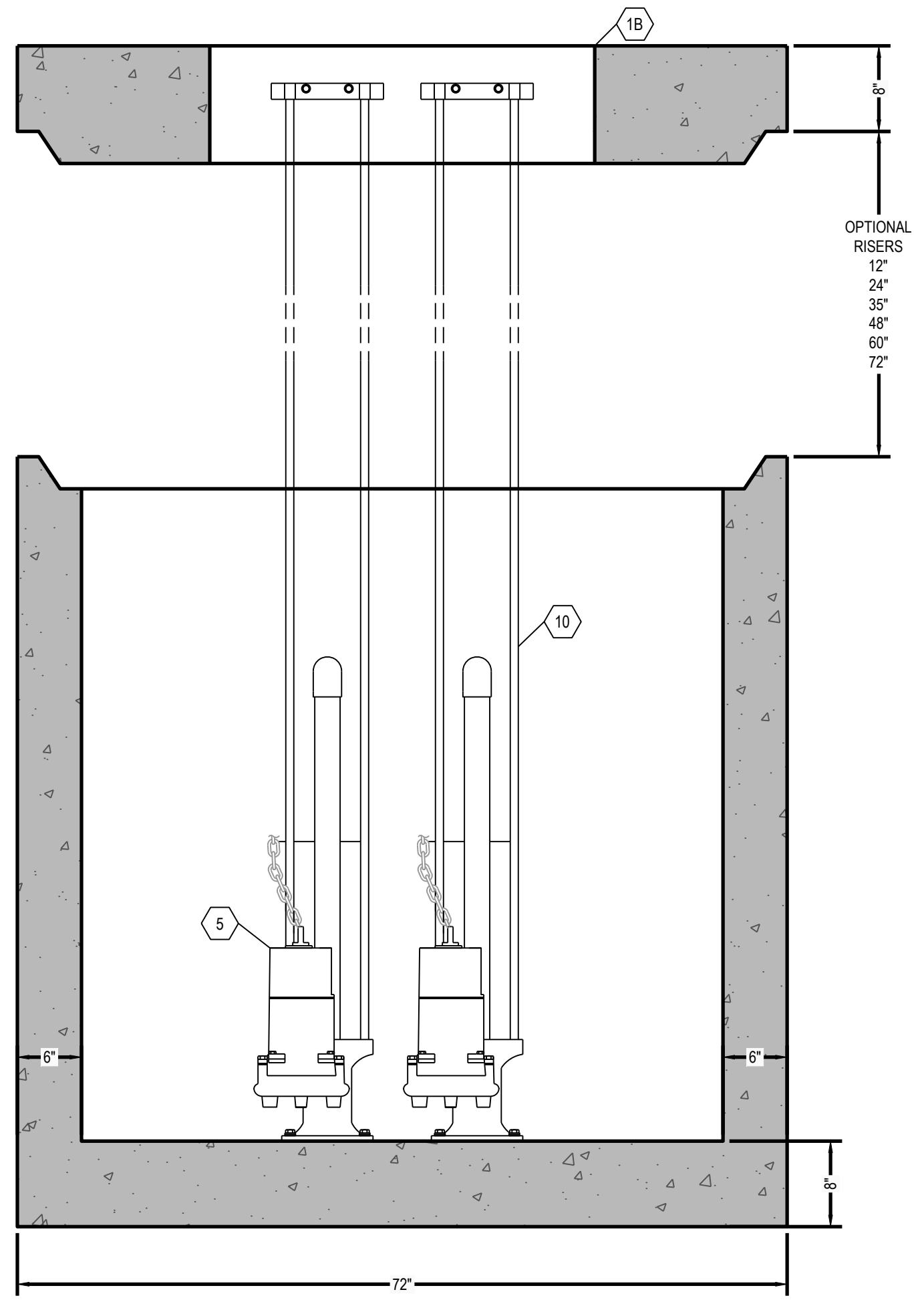

A4 LIFT STATION SECTION VIEW
1" = 1"

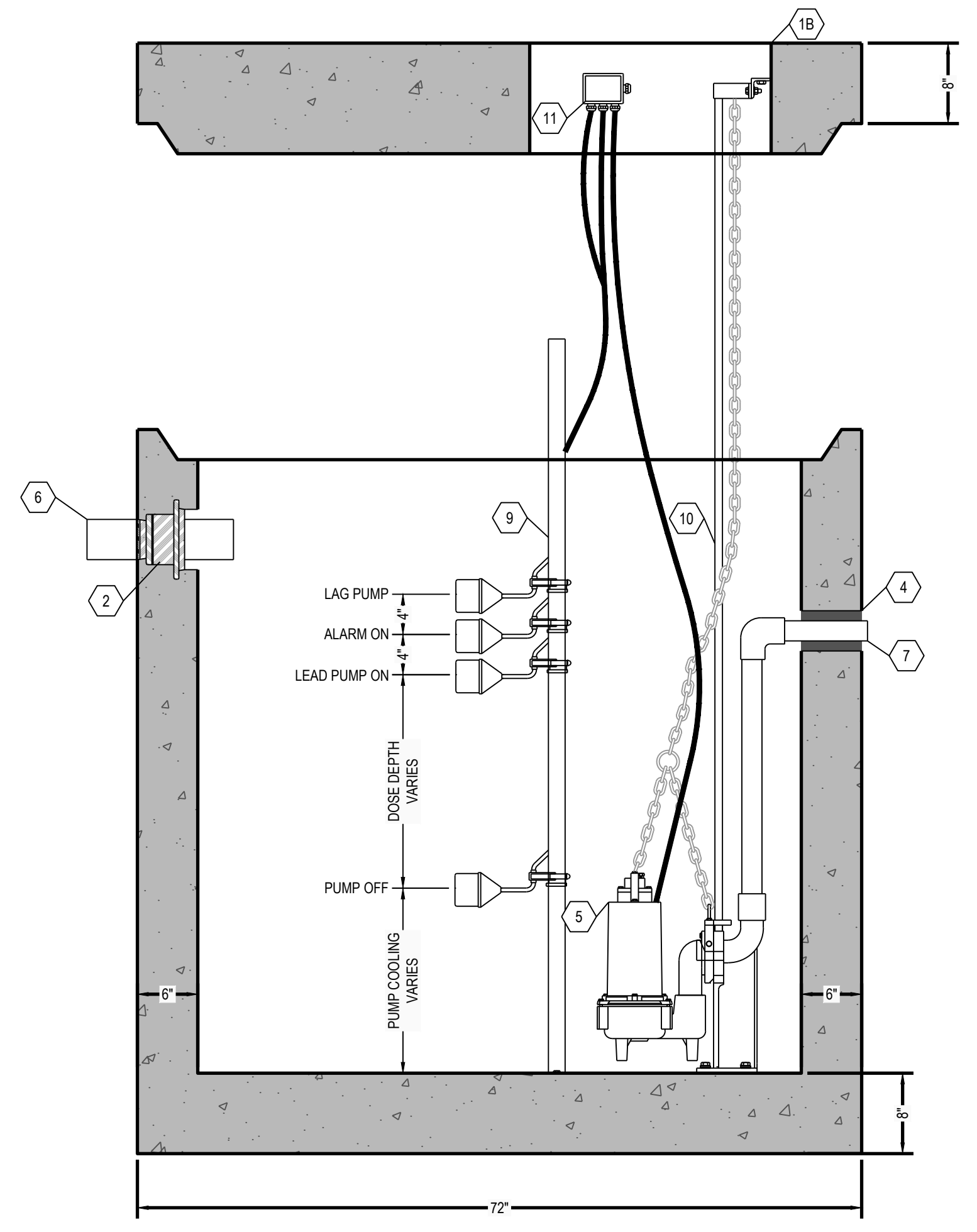

A3 LIFT STATION SECTION VIEW
1" = 1"

KEYNOTE INDEX

1A	24", 36" OR 48" SQUARE MANWAY
1B	CUSTOM HATCHES AVAILBLE
2	FLEXIBLE RESILIENT PIPE TO MANHOLE CONNECTORS MEETING ASTM C-923 AVAILABLE UPON REQUEST
3	MASTIC ROPE
4	TS-4PRO RUBBER GASKET SEAL BY TUF-TITE
5	DOSING PUMP
6	X" DIAMETER INLET VARIES
7	X" DIAMETER OUTLET VARIES
8	OPTIONAL OVERSIZED BASE
9	FLOAT POLE ASSEMBLY WITH STAINLESS STEEL HARDWARE
10	RAIL SYSTEM WITH STAINLESS STEEL RAILS & HARDWARE
11	WATERTIGHT ELECTRICAL JUNCTION BOX

*** ALL RENSELAER SEPTIC TANKS ARE MONOLITHICALLY POURED ***