

C6 COMBO TANK TOP VIEW
1" = 1"

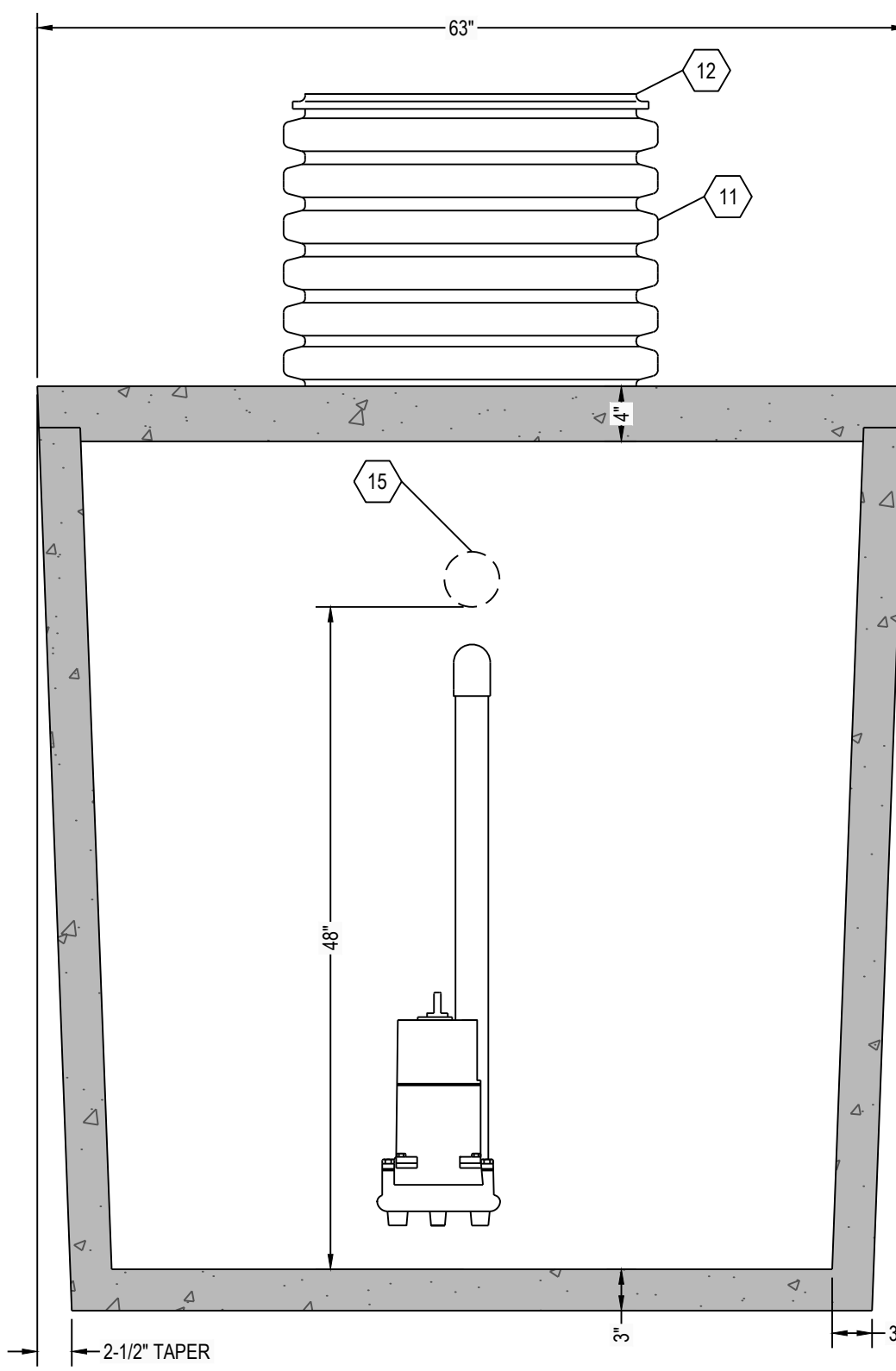

C4 COMBO TANK SECTION VIEW
1" = 1"

- DESIGN DATA:**
- EARTH COVER = 3 FEET MAX
 - ALLOWABLE WHEEL LOAD = 2500 LB MAX
 - CONCRETE MINIMUM COMPRESSIVE STRENGTH = 5,000 PSI @ 28 DAYS
 - LIFTING HOOKS ARE 1" DIAMETER, ASTM A36 COLD ROLLED STEEL
 - COMBO TANK LID IS REINFORCED WITH 6 X 6 W8.0 X W8.0 WELDED WIRE FABRIC.
 - COMBO TANK BOTTOM AND SIDES ARE REINFORCED WITH 6 X 6 W10.0 X W10.0 WELDED WIRE FABRIC.
- IPANEX**
- ALL CONCRETE IN THIS PRODUCT CONTAINS IPANEX, AN ADMIXTURE TO WATERPROOF THE CONCRETE AND PROVIDE CORROSION CONTROL

- CASTING WEIGHTS**
- WEIGHT OF LID: 2,725.0 LBS
 WEIGHT OF TANK: 7,744.5 LBS
 TOTAL CASTING WEIGHT: 10,469.5 LBS
- SEPTIC COMPARTMENT CAPACITY:**
 LIQUID STORAGE = 972 GALLONS
 19.4 GALLONS PER INCH
- DOSING COMPARTMENT CAPACITY:**
 LIQUID STORAGE = 528 GALLONS
 10.6 GALLONS PER INCH
 MAXIMUM DOSE = XXX GALLONS (XX")
 PUMP COOLING = VARIES
 UNUSED (ALARM) = 42 GALLONS (4")
 TOTAL = XXX GALLONS (XX")

- NOTES:**
- SET PUMP ON FLOAT SWITCH ELEVATION ACCORDING TO ELEVATION TABLE (BELOW); WHICH YIELDS THE REQUIRED DOSE VOLUME OF XXX GALLONS.
 - CONTRACTOR SHALL INSTALL CONTROL PANEL ACCORDING TO PUMP MANUFACTURER'S RECOMMENDATION.
 - COORDINATE POWER & ALARM SERVICE PRIOR TO CONSTRUCTION ACTIVITIES
 - ONLY NON-CORROSIVE MATERIALS SHALL BE UTILIZED WITHIN THE DOSING TANK AND FOR THE RISER AND LID (NO GALVANIZED, PAINTED, OR EXPOSED STEEL)
 - AUDIO VISUAL ALARM CIRCUIT MUST LOCK ON WITH ANY PUMP FAILURE WITH MANUAL RESET.
 - THE INLET PORTS THROUGH THE INTERIOR WALL SHALL BE PROVIDED WITH A SANITARY TEE AND TS-4PRO RUBBER GASKET SEAL BY TUF-TITE. THE SANITARY TEE SHALL BE LOCATED OUTSIDE THE PUMP VAULT (IN THE SEPTIC COMPARTMENT). A 12" LONG DOWNWARD EXTENSION SHALL BE PROVIDED AT THE SANITARY TEE. AN UPWARD EXTENSION SHALL BE PROVIDED AT THE SANITARY TEE SUCH THAT THE TOP OF EXTENSION EXTENDS BEYOND THE ALARM ELEVATION.

DOSING CHAMBER ELEVATIONS

DESCRIPTION	ELEVATION (FEET)
BOTTOM OF CHAMBER	0.00
PUMP OFF	1.08
PUMP ON	2.83
ALARM	3.17
LAG PUMP ON	N/A

NOTE:

- 24" DIAMETER POLY RISERS OR CUSTOM RECTANGULAR RISERS WITH ALUMINUM HATCHES ARE AVAILABLE AS SUBSTITUTES TO POLY RISER AS SHOWN HEREON.
- HIGH PRESSURE CLOSED END BOOT SEALS ARE AVAILABLE AS SUBSTITUTES TO RUBBER GASKET TYPE SEALS AS SHOWN HEREON.

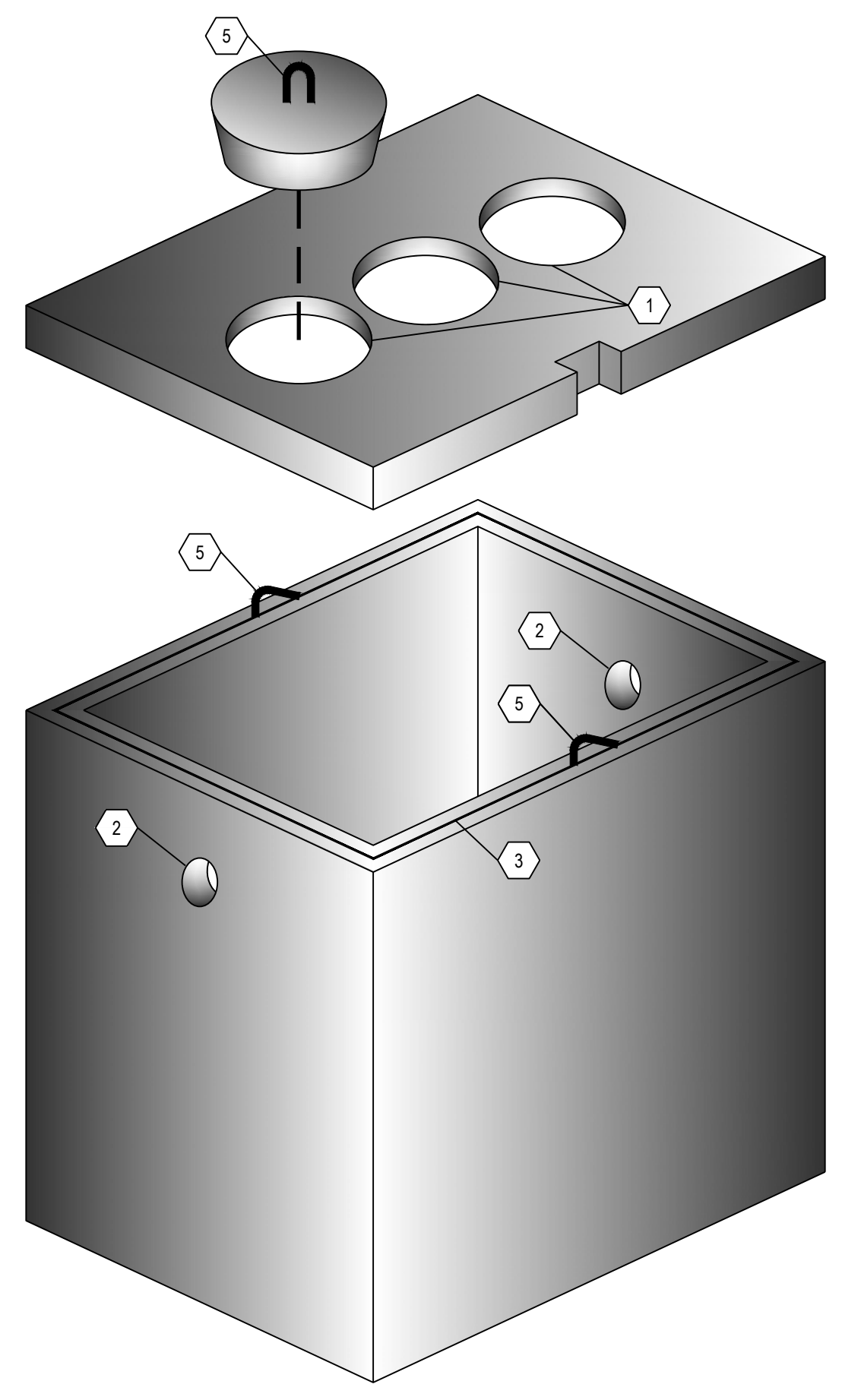

A6 THREE DIMENSIONAL ISOMETRIC VIEW
NTS

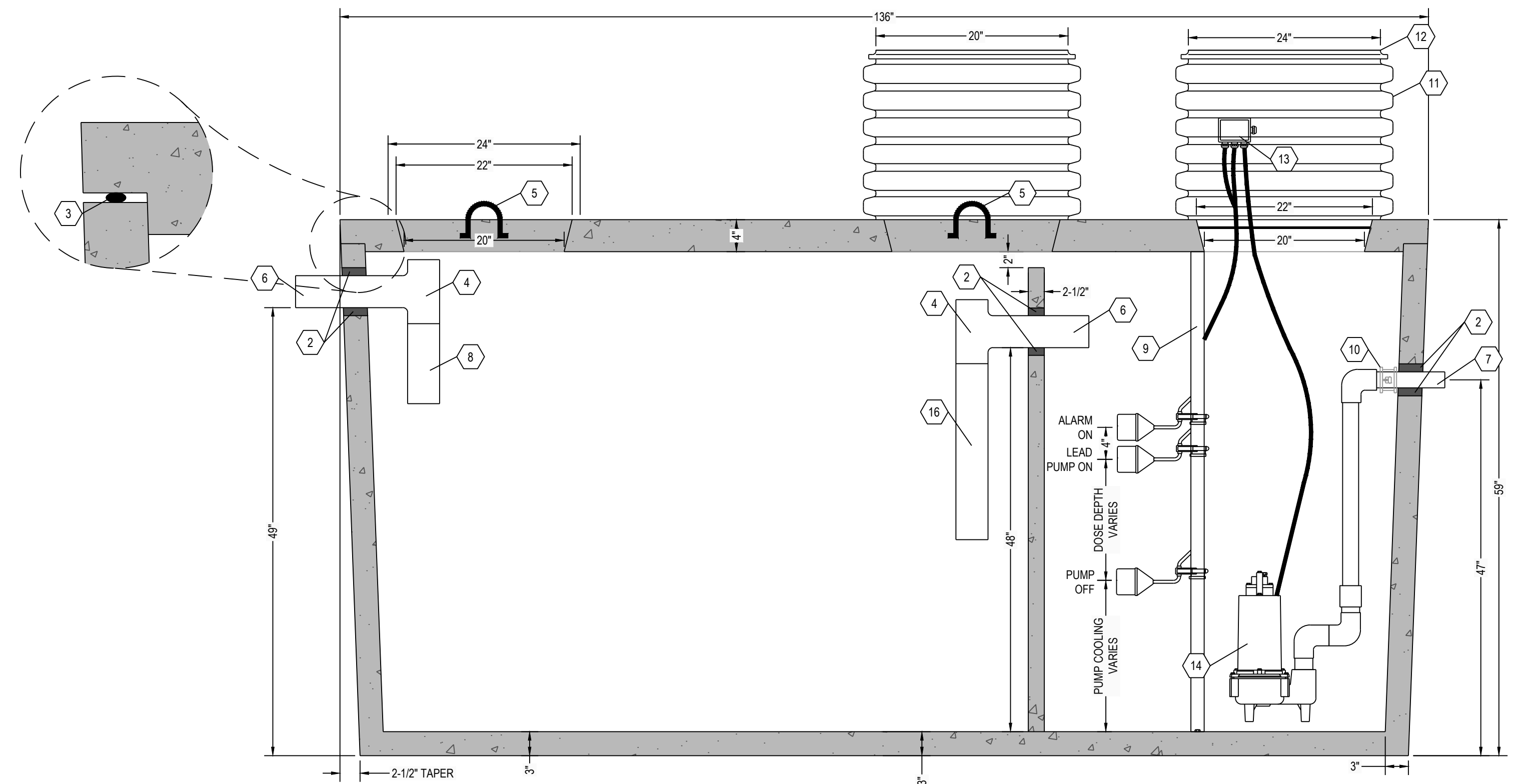

A5 COMBO TANK SECTION VIEW
1" = 1"

KEYNOTE INDEX

1	20" DIAMETER MANHOLE OPENING
2	6" POLYLOK TYPE VI BOOT SEAL OR 2" PRESS SEAL
3	MASTIC ROPE
4	SANITARY TEE AT INLET
5	1" DIAMETER LIFTING HOOKS
6	4" or 6" DIAMETER INLET
7	X" DIAMETER OUTLET
8	12" EXTENSION AT INLET
9	FLOAT POLE ASSEMBLY WITH STAINLESS STEEL HARDWARE
10	X" DIAMETER BANJO® POLYPROPYLENE QUICK DISCONNECT
11	24" DIAMETER POLY RISER (18" HEIGHT TYP)
12	24" DIAMETER GAS TIGHT POLY SNAP CAP LID AFFIXED WITH STAINLESS STEEL SCREWS
13	WATERTIGHT ELECTRICAL JUNCTION BOX
14	DOSING PUMP
15	ONE (1) 4" DIAMETER PORT THROUGH INTERIOR WALL - SEE NOTE 6
16	24" EXTENSION AT INLET

RENSELAER SEPTIC TANKS

1211 NORTH WESTON STREET
 P.O. BOX 70
 RENSELAER, INDIANA 47978
 phone: (219) 866-5063
 (800) 240-5123
 fax: (219) 866-3894

PROJECT NAME
 CLIENT NAME
 ADDRESS

PROJECT NO: ---
 FIG#00 GAL- DUAL- NT- SIMPLEX-P-NR.DWG
 DRAWN BY: ASJM
 CHECKED BY: PEW
 TITLE:
**MANUFACTURER'S
 DETAIL DRAWING**
 1500 GALLON COMBO
 NO TRAFFIC
 SIMPLEX DOSING

R-000

* ALL RENSELAER SEPTIC TANKS ARE MONOLITHICALLY Poured *